



Application: Residential

Location: Woking, Surrey

System: Standard Ramp System

Service Package: Supply & Install

CASE STUDY: **Woking, Surrey**

A FLEXIBLE RAMP DESIGN WITH SPACE FOR PARKING

REQUIREMENT: Ramped access to a dwelling.

This adaption was funded with a disabled facilities grant (DFG).

ADDITIONAL INFORMATION: Due to the lack of on-street parking, the occupational therapist requested a design that would allow space for a car on the drive.

Our in-house designer was able to accommodate this request, as shown in the 3D CAD drawing.

Lidar scanning technology was used during the site surveying process. The machines scanned and virtually mapped out the whole area, including the building and varied terrain levels.

Our designer then plotted a 3D visual of the ramp on top of the lidar model. This technology enables us to continue to carry out site surveys efficiently and within a minimal time frame.

The final CAD designs were given to the client with their quotation.



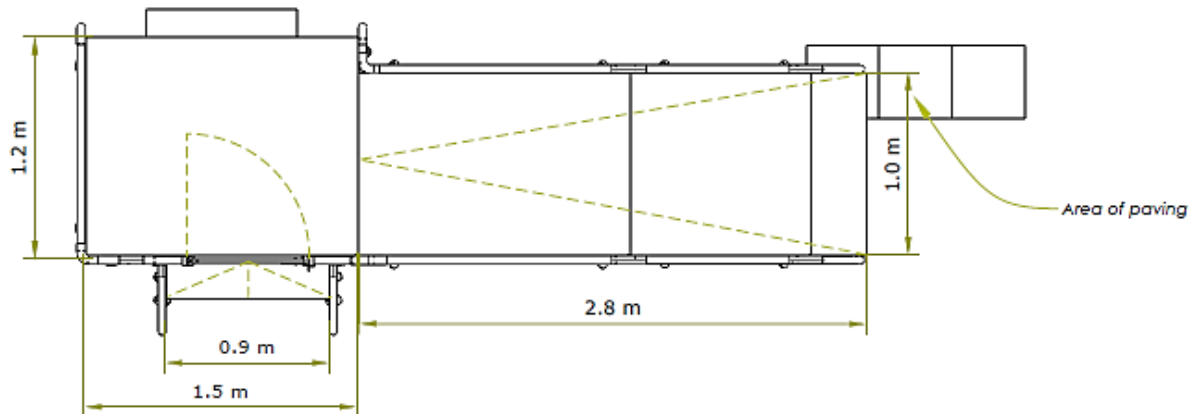

END RESULT: The ramp was installed within a few hours and included a 1:12 gradient.

This is the minimum gradient expected for dwelling ramps to achieve under [Document M and K of the building regulations](#).

FEATURES INCLUDED:

- Mesh Platform - the self-draining mesh allows water to pass through rather than collect on the surface.
- Trombone Ends - these are added to the ends of a Rapid Ramp to prevent clothes catching.
- Standard Handrail - this handrail system ensures users always have support to hold onto.
- Powder coated Finish – Rails are coated with thermosetting powder to provide a non-conductive, non-slip and scratch resistant surface.
- Telescopic Legs - these can be adjusted to accommodate different threshold heights.

EXTRA FEATURE INCLUDED:

- Step & Gate Unit - access for able-bodied users.
- Yellow Tread Strips On Step unit - this is a safety feature designed to help those with impaired vision identify the nose of the step.

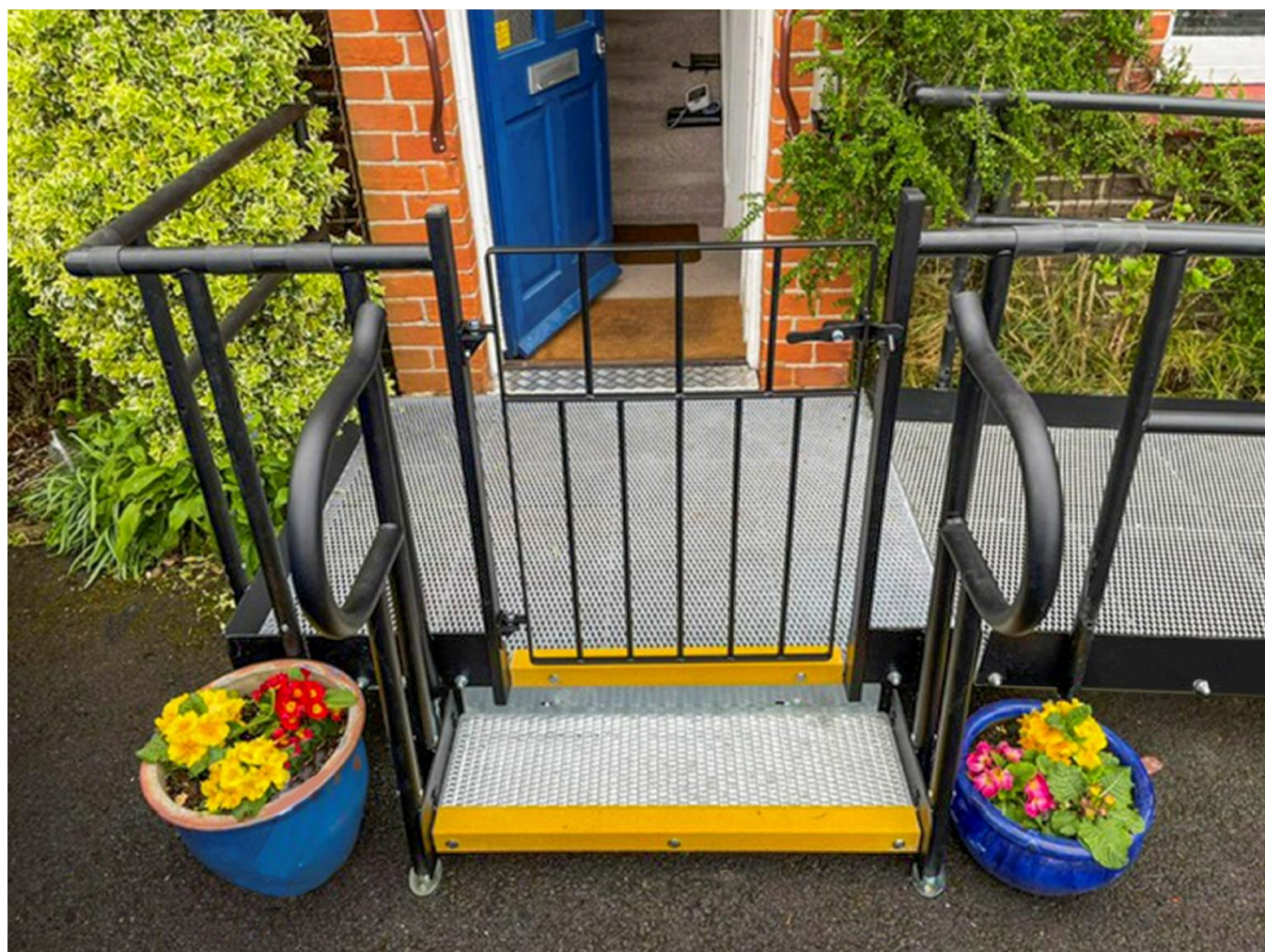



TEL: **01424 714646**
EMAIL: **SALES@RAPIDRAMP.CO.UK**

Hours:
Open 8am - 5pm, Monday to Friday
Address:
10 Menzies Road, Ponswood Industrial Estate, St Leonards on Sea, East Sussex TN38 9BB

Do you require wheelchair
ramps and steps?

Contact our sales team